

PARTS LIST

Front under spoiler

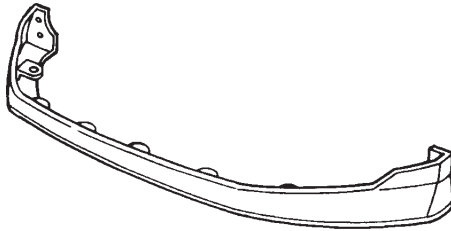

4 Washer-bolts



4 Clip nuts



4 Self-tapping screws



4 Spring nuts

**TOOLS AND SUPPLIES REQUIRED**

Phillips screwdriver

Ratchet

10 mm Socket

10 mm Combination wrench

Piece of cardboard

Pushpin

INSTALLATION

Customer Information: The information in this installation instruction is intended for use only by skilled technicians who have the proper tools, equipment, and training to correctly and safely add equipment to your car. These procedures should not be attempted by "do-it-yourselfers."

NOTE:

- Be careful not to damage the front bumper and other finished surfaces of the body.
- To prevent damage, rest the front under spoiler on a piece of cardboard during the assembly.

1. Wash and wax the area to be covered with a high-quality wax.
2. Remove the three washer-bolts from the front bumper.

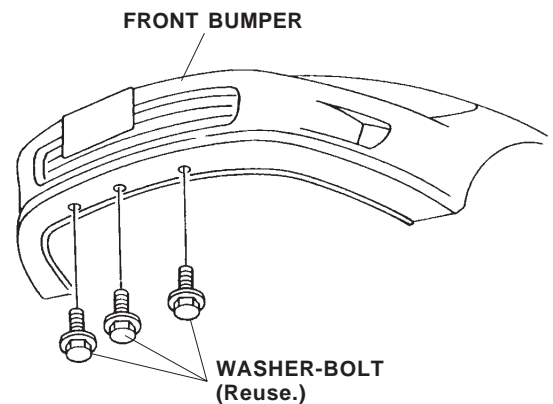

- Slide one clip nut over each cutout in the lower edge of the front bumper.

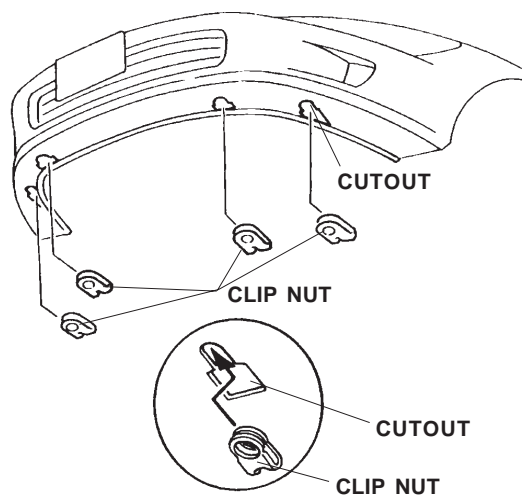

- Position the front under spoiler on the front bumper, and reinstall the three washer-bolts you removed in step 2.

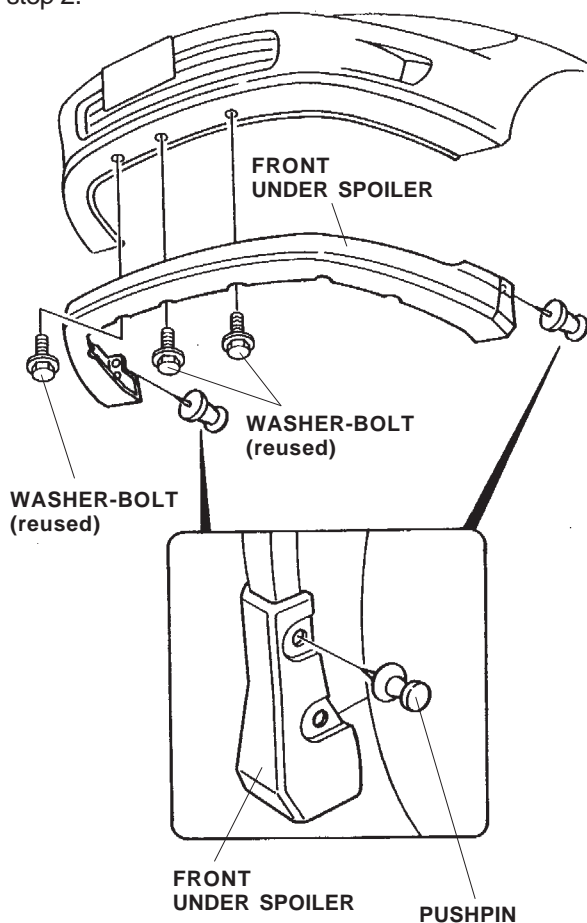

- Position the under spoiler along the fenderwell, and align the lower hole in the under spoiler with the hole in the fenderwell. Using a pushpin, mark the front bumper through the upper hole. Repeat on the other side.

- Install the four washer-bolts included in the kit.

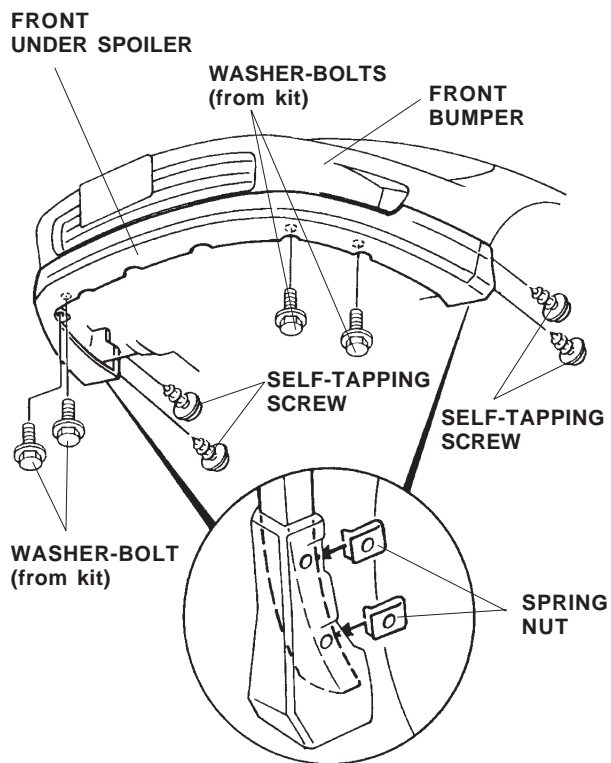

- Slide one spring nut over the lower hole along the fenderwell and one over the hole you made with the pushpin in step 5. Repeat on the other side.
- Install two self-tapping screws on each side of the vehicle through the spoiler and into the fenderwell. While holding the under spoiler firmly against the front bumper, tighten all of the bolts and screws.