



INSTALLATION INSTRUCTIONS

Accessory

ARMREST

Application

**2005 CIVIC (DX)
2- AND 4-DOOR**

Publications No.

All 28282

Issue Date

NOV 2004

PARTS LIST

Armrest

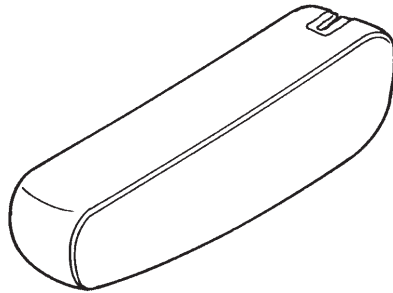

Armrest mount

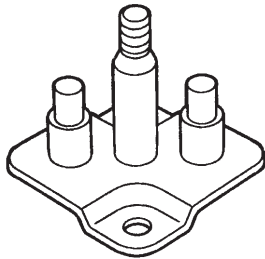

2 Washer-bolts, 6 x 16 mm



Plain washer



2 Bushings

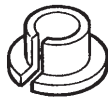

Wave washer



Cap nut



TOOLS AND SUPPLIES REQUIRED

Ratchet

10 mm and 17 mm Sockets

Utility knife

Felt-tip pen

Tape measure

Torque wrench

INSTALLATION

NOTE: Be careful not to damage the seat cover.

1. Using a tape measure and a felt-tip pen, measure and mark the seat-back.

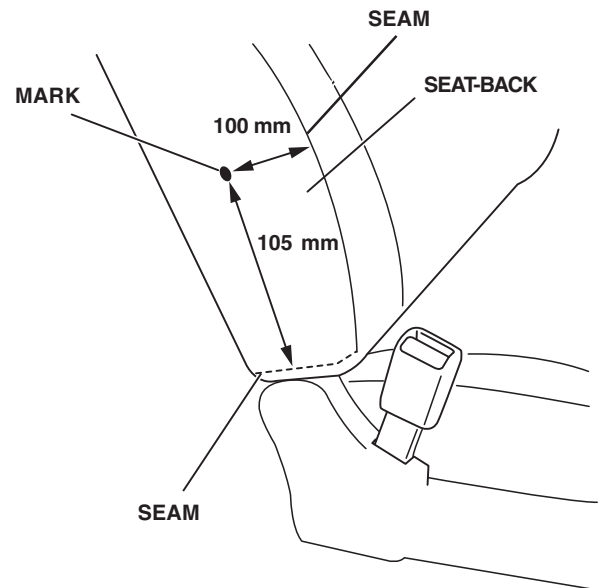

2. Push in on the mark, and confirm that the mark is centered over the hole in the seat base.

- Using a utility knife, make two 70 mm cuts in the seat cover through the mark at right angles to each other as shown. Use these 70 mm cuts as a guide to cut out the marked area from the seat urethane to expose the seat base.

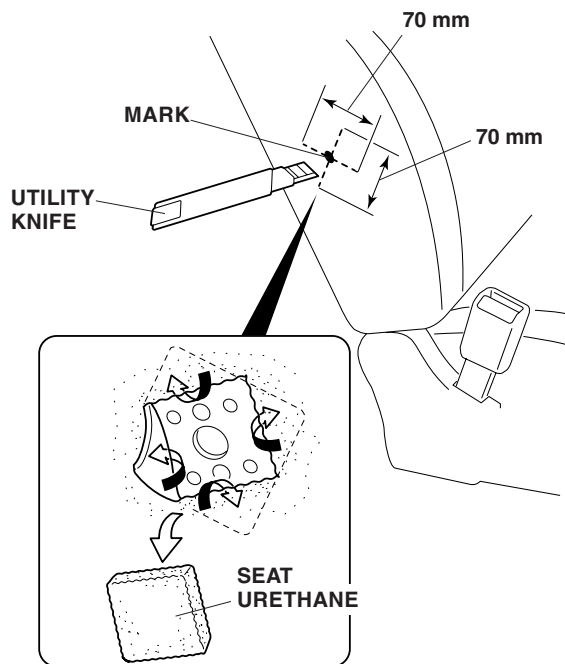

- Position the armrest mount on the seat base, and install the two 6 x 16 mm washer-bolts. Torque the two 6 x 16 mm washer-bolts to 10 N•m (7 lb-ft).

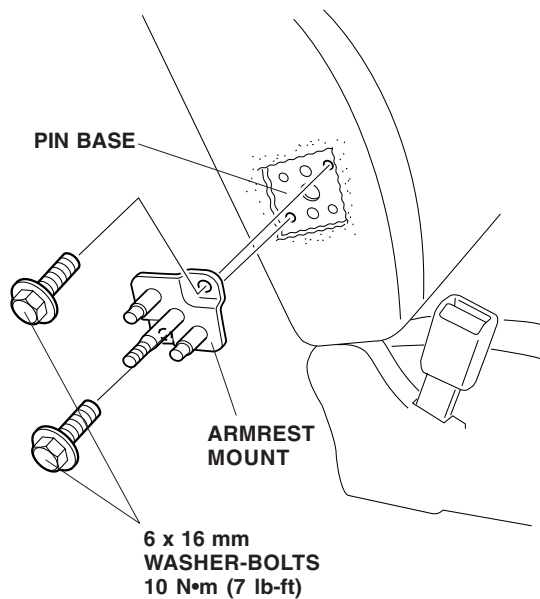

- Zip open the armrest cover, and turn over the cover as shown.

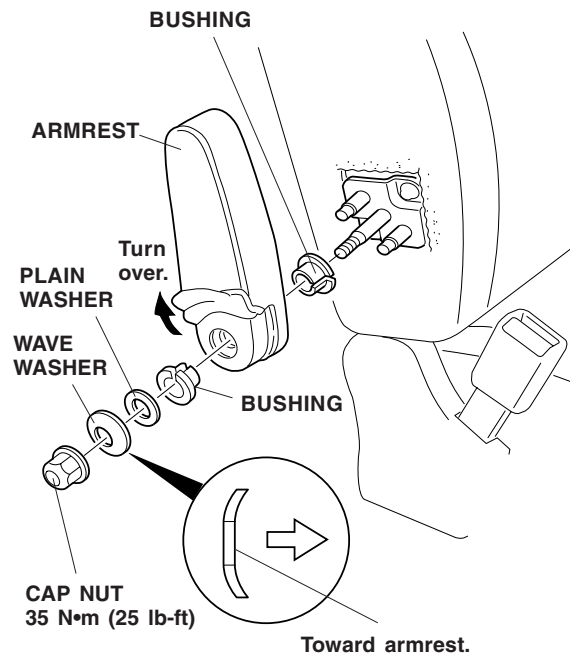

- Install the bushings to both sides of the armrest. Install the plain washer, the wave washer (with the base facing the plain washer), and the cap nut in the order shown. Torque the cap nut to 35 N•m (25 lb-ft).
- Reinstall the armrest cover, and zip the cover closed.
- Check that the armrest moves up and down smoothly.